



# **GARAGE DOOR OPENER INSTALLATION MANUAL**

Comply to: SANS IEC 60-335-2-103  
NRCS Cert. no. 155969/002

DTS 1000

DTS 1000HS

**DTS SECURITY PRODUCTS**

Spartan +27 11 392 5540 (H/O)  
Pretoria +27 12 361 5528

[www.dtssecurity.co.za](http://www.dtssecurity.co.za)

# CONTENTS

Important safety recommendations.....	1-2
Basic function introduction.....	3
Installation.....	4
Installation (aluminum track).....	5-6
Installation (one-piece steel track).....	7-8
Installation recommendations.....	8
Basic function setting.....	9-10
Special function introduction (optional).....	11
Wiring guide.....	12
Manual disengagement.....	13
Maintenance.....	12
Final notes.....	14
Important information for the user.....	14
Technical Specifications.....	14
Standard packing list.....	15
General error code.....	15
Manufacturers warranty.....	16

To the extent that they may be lawfully excluded, DTS Security Products hereby expressly excludes all conditions and warranties, statutory or otherwise, which may be implied by law as conditions or warranties of purchase of a Garage Door Opener. DTS Security Products hereby further disclaims and rejects to the maximum extent permitted by law any liability or responsibility whatsoever for any direct, indirect, consequential, or other injury, damage, cost, expense or loss whatsoever incurred or suffered by any person, company, firm, or organization as a result of any failure to install the Garage Door Opener in accordance with these installation instructions.

## Important safety recommendations

The new GDO is professionally designed under the newest design idea. The installation and setting of this GDO are extremely easy. It has complete functions, giving the users a relaxed and happy installation experience.

### Safety Warnings:

Warning: It is very important to read this safety warning and follow all instructions before installing.

Or it may cause serious personal injury and/or property loss. Save these instructions.

1. This appliance should not be used by children or persons with reduced physical, sensory or mental capabilities without supervision.
2. We strongly recommend installing photo beams to increase safety protection and psychological security.
3. Before installing the drive, remove any unnecessary ropes or chains and disable any equipment, such as locks not needed for powered operation. Check that the door is in good mechanical condition, balanced and opens and closes properly.
4. A-weighted emission sound pressure level of the drive  $L_{pA} \leq 70$  dB(A).
5. The operator must not be used for doors without a safety catch.
6. Install the actuating member for the manual release at a height of less than 1,8 m. If removable, the actuating member should be stored in the direct vicinity of the door.
7. Install any fixed control at a height of at least 1,5 m and within sight of the door but away from moving parts.
8. Wall switch or wall transmitter must be installed out of the reach of children.
9. Permanently fix the labels warning against entrapment in a prominent place or near any fixed controls.
10. Permanently fix the label concerning the manual release adjacent to its actuating member.
11. After installation, ensure that the mechanism is properly adjusted and that the drive reverses or the object can be freed when the door contacts a 50 mm high object placed on the floor. Ensure that parts of the door do not extend over public footpaths or roads – repeat the test monthly.
12. Refer to pages 4-8 for information on how to adjust the door and drive.
13. Connect the GDO to the 220V AC circuit and fix it to the required place by a professional person.

**WARNING:** The drive shall be disconnected from its power source during cleaning, maintenance and when replacing parts.



14.  Electrical waste products should not be disposed of with household waste. Please recycle where facilities exist. Check with your local authority or retailer for recycling advice.
15. If the supply cord is damaged, it must be replaced by the manufacturer, its service agent, or a similarly qualified persons in order to avoid a hazard.
16. Watch the moving door and keep people away until the door is completely opened or closed.
17. Take care when operating the manual release since an open door may fall rapidly due to weak or broken springs, or being out of balance.
18. Check the condition of the door frequently if it has any damage or if it is well balanced, especially the cable, spring and components connect to the wall. Don't use the door if it is not repaired or adjusted, or there will be injury due to improper installation or bad balance. If the door components are under extreme pressure, don't repair them by yourself, if necessary, call for authorized service.
19. The drive must not be used with a door incorporating a wicket door (unless the drive can not be operated with the wicket door not put in the safe position). If applicable, the drive is not to be used with doors having openings exceeding 50 mm in diameter or having edges or protruding parts a person could grip or stand on.
20. Don't open/close the door when people are near the door. Keep children away from the moving door. Or it may cause serious personal injury and/or property loss.
21. In order to keep the GDO away from the rain, don't expose it outdoors. Don't put the GDO in the water, don't spray water on the GDO, and keep the GDO away from any other device with water.
22. In order to make sure the GDO can sense the obstacle under the door, the door must press the obstacle. So, it may cause injury or damage to the obstacle, door, or person.
23. If the circuit is damaged, return the unit for repair.
24. Make sure the garage door is fully open & stationary before passing through the door. Make sure the garage door is fully closed & stationary before leaving.

The device is intended for the opening and closing of tilt-up and sectional garage doors in the private sector.

For DTS 1000, it is best for the door to be less than 14m<sup>2</sup>, 140kgs.

For DTS 1000HS, it is best for the door to be less than 14m<sup>2</sup>, 140kgs.

## Basic function introduction

1. Soft start, soft stop. Minimize start-up load on garage door opener and garage door
2. The door will stop during opening when contacting obstruction and will reverse at least 300mm during the closing when contacting obstruction.
3. Opening & closing force dynamic self-learning. Can make sure the garage door driver will work steadily in spite of changes in door resistance by seasonal variation.
4. Safety resistance adjustable with a wide range, sensitive and reliable.
5. Overloading force detecting, the door will reverse more than 150mm automatically when it is overloaded when closing and will stop when it is overloaded when opening.
6. Low-voltage protection, the process will not perform any action of opening and closing when the voltage is too low, door panel and controller won't be damaged.
7. We adopt a rolling code transmitter, with billions of codes, which won't be coincident code or pirated code.
8. Auto-close function available.
9. Backup battery interface available, in case of power failure.
10. Wall switch interface available.
11. Photo beam interface available, the door will change to open when obstruction is detected while closing.

## Installation

- 1). Read the instructions carefully.
- 2). Make sure the door structure is solid and suitable to be motor driven.
- 3). Make sure that when the door is moving there are no friction points.
- 4). The door must be properly balanced and must be easily lowered and raised by hand.
- 5). Install a 220V AC adequately protected 3-pin socket near where the GDO is going to be installed.

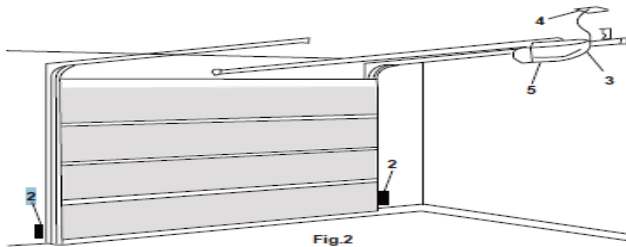
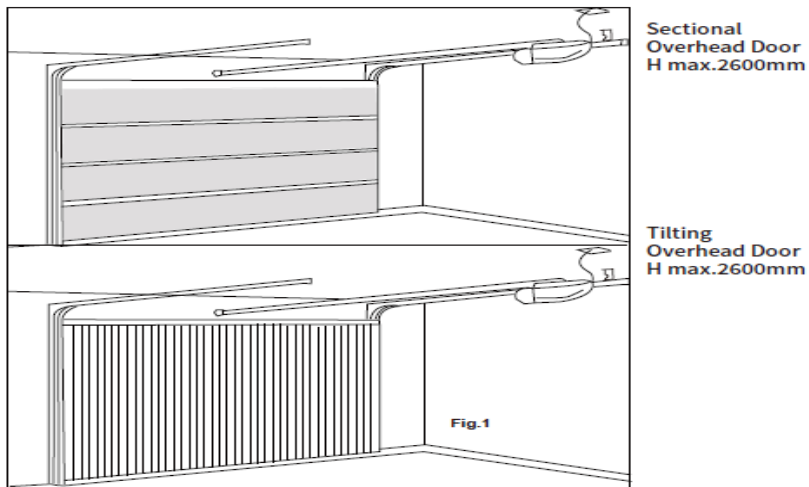

Referring to Fig. 2 for recommended installation

- 1) Extrusion
- 2) Photo beams (optional)
- 3) Inside push button panel (Optional)
- 4) Power point
- 5) Sectional door opener

## Chain Shuttle Assembly.

For ease of installation, the opener is delivered with the chain and chain shuttle already assembled in the track. If you need to assemble it yourself, connect the chain shuttle to the chain with screw C tightened firmly. Move shuttle B to halfway along the rail section, grease the chain and sprocket (Fig. 3) with a lithium-type grease or equivalent. Do not use oil-type lubricants.

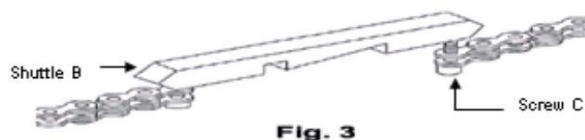

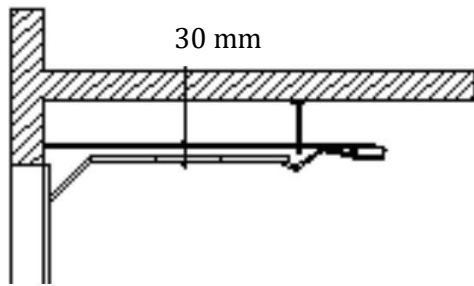

Fig.4

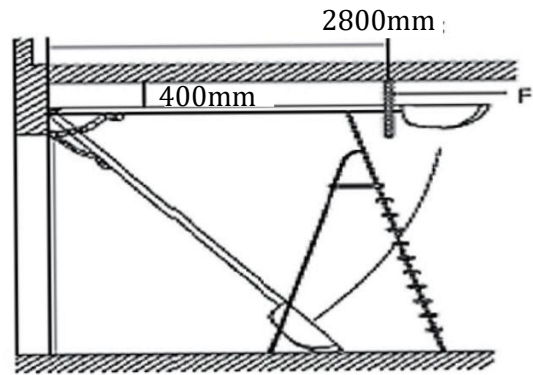

Fig.5

Maintain a minimum gap of 30mm from the top panel's maximum height (Fig.4).

Make sure the track is horizontal and vertical to the shaft. Make sure the connection of hanging bracket F and The ceiling is firm enough (Fig. 5).

**Warning:** Make sure the opener is affixed to noggins in the ceiling and not to the plasterboard. Failure to have a safe and secure fixing will lead to the opener falling, and causing serious personal and /or property damage.

### Installation (aluminum track)

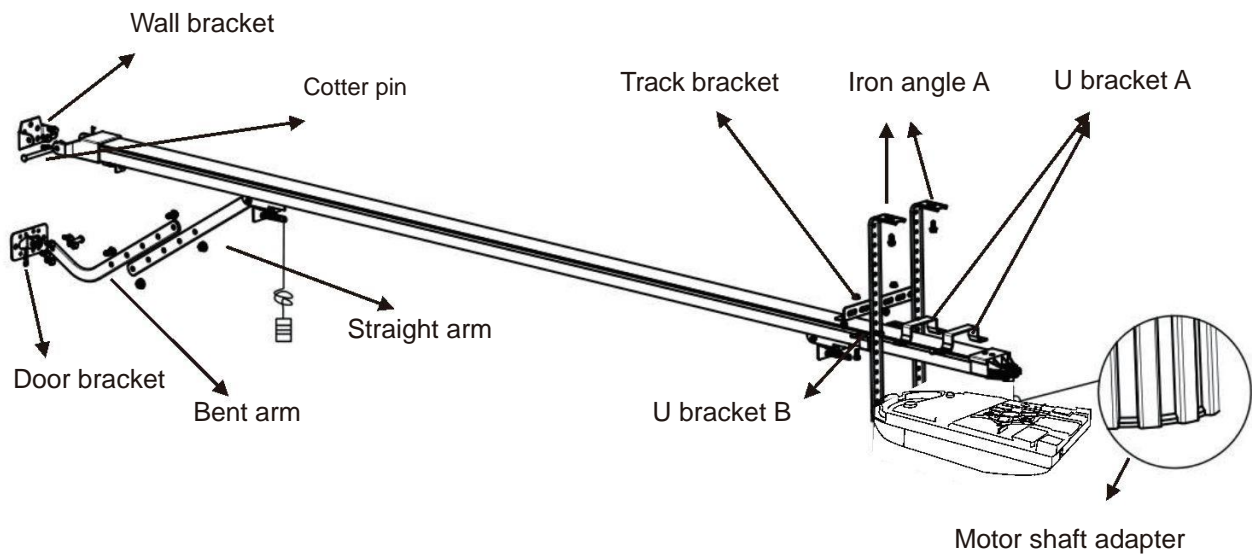

Fig.6

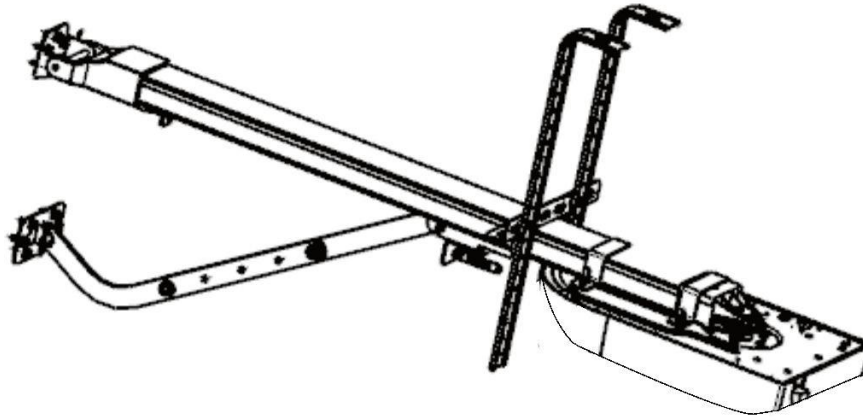

Fig.7

## Installation procedure

1. Fixing the wall bracket. Fixing the wall bracket to the wall 20-150mm over the shaft or intermediate bracket (depending on the actual installation space).
2. Fixing the steel track to the wall bracket with a cotter pin.
3. Sleeve the motor shaft adapter to the motor shaft according to Fig. 6.

Notice: the flanged end facing down.

4. Fixing garage door opener to the track by U bracket A. It's enough for a 2 Nm fastening force.
5. Fixing the iron angle A to the wings of the garage door opener base plate, hanging the track to the ceiling by iron angle A.

**Notice:** Make sure the connection of iron angle A and the ceiling is firm enough. Make sure the track is horizontal and vertical to the shaft.

6. Fixing the door bracket on the door panel, fixing the straight arm and bent arm, and fixing the traveller cord.
7. Release the traveller, and try to open and close the door by hand. Make sure there is no resistance between the door panel and the track.
8. Connect the opener with power and adjust the operation.

**Notice:** Make sure the opener's voltage is in accordance with the local voltage. Connect the opener to a properly earthed power supply



# Installation (one-piece steel track)

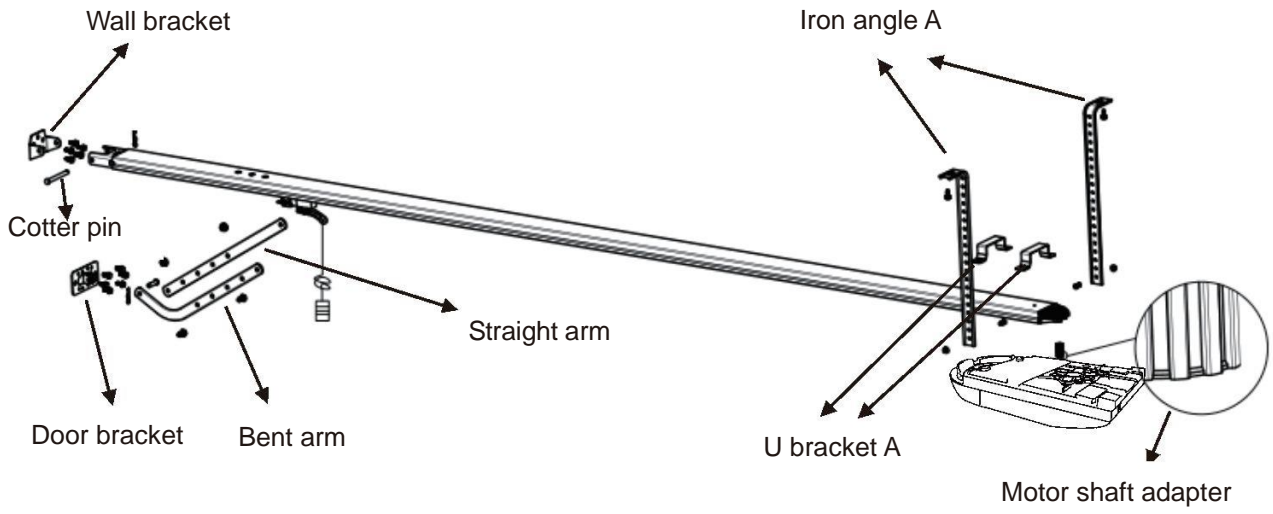

Fig.8

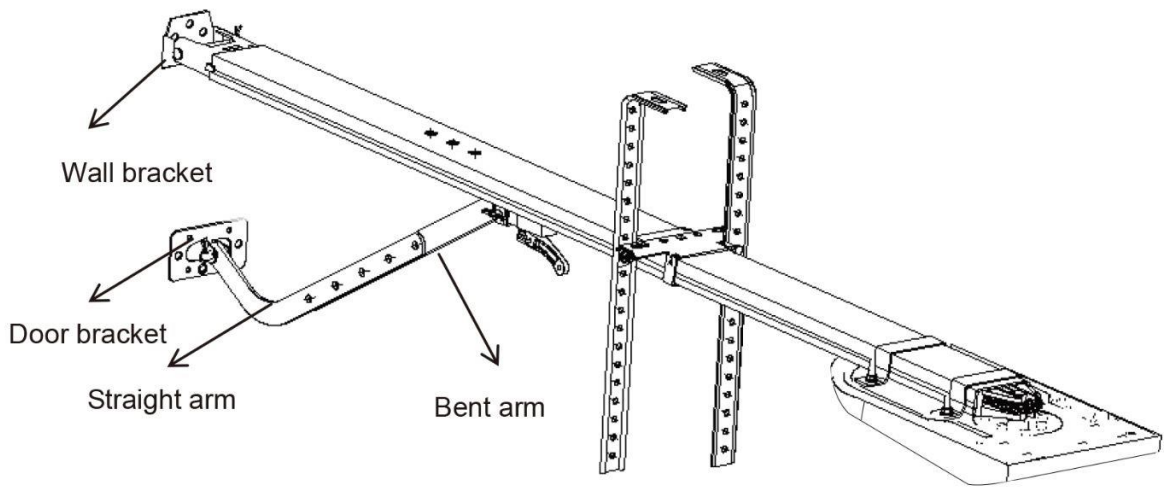

Fig.9

## Installation recommendations

Remember there are specific standards that have to be strictly followed regarding the safety rules of electrical installation and automatic doors. As for the legal requirements and standards that must be adhered to, please take notice of the following points to ensure maximum safety and reliability of your installation.

1. Before installing check the surrounding environment. Carefully evaluate any hazards which could be physical damage (transiting vehicles, parts of trees falling, etc.), possible contact with persons, insects, leaves, flooding hazards or any other exceptional events.
2. Check the main voltage numbers are the same as the numbers that are given on the rating plate in this manual.
3. Check and make sure there is suitable electrical protection against short circuits/power spikes and proper earthing on the main supply.

**Remember the unit has main voltage running through it (electrocution hazard, fire hazard).**

4. Take care of the control unit, the parts may be subject to damage if the control unit is abused.
5. Make sure that you have all the necessary materials and that they are suitable for this kind of use.
6. Read all the instructions thoroughly and make sure they are understood before attempting to install the opener.
7. Before starting the installation carefully analyze all the risks relating to automating the door. Verify that the door is automated in sound condition and that the mechanisms are in good working order. Observe the safety margins and minimum distances.
8. Carefully evaluate the safety devices to be installed and the right place to install them, always install an emergency stop device for power interruption to the opener if it is required.
9. Once the risks have been analyzed, install the opener and relative safety devices, emergency stop, and/or photo beams.

**Important note:** As for additional safety rules, we strongly recommend the fitting of Photo beams on all installations.

10. While installing the opener, strictly follow all the instructions given in the instruction manual. If some points or procedures in this manual are not very clear do not install the unit until all doubts have been cleared up with our technical department.

# Basic function setting

## 1. Limit setting Opening & Closing force dynamically self-learning

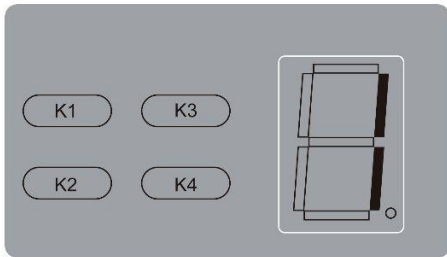

Fig. 1

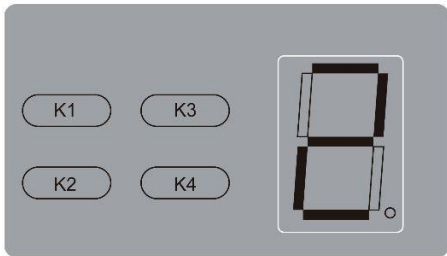

Fig. 2

Press and hold 'K1' until the LED displays figure '1', like in Fig. 1, and then adjust the open limit by pressing the 'K3' button. Fine-tuning with 'K3' or 'K4' buttons to determine the final open limit position then pressing the 'K1' button, the display turns to '2' automatically, like in Fig. 2. Adjust the close limit by pressing the 'K4' button. Fine-tuning with 'K3' or 'K4' buttons to determine the final close limit position then pressing the 'K1' button to confirm. The garage door opener will operate a cycle automatically to remember the limit positions and the opening & closing force.

## 2. Matching the receiver and transmitter

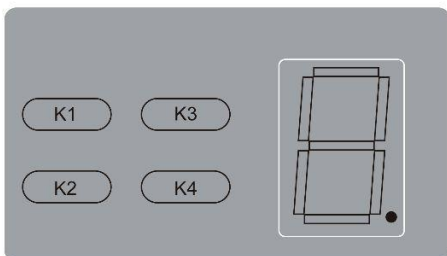

Fig. A

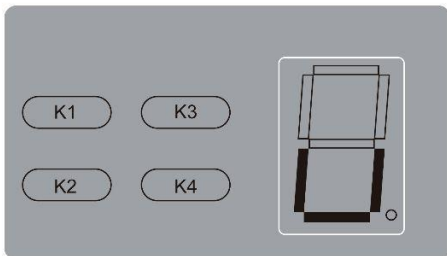

Fig. B

Press and hold 'K2' until the LED dot appears. (Fig. A)

Then press any button on the transmitter, and the dot will be off; press the button again the dot will fast flash then the LED displays 'u' (Fig. B). After that, the transmitter will be available. It will be able to control the opening, closing, and stopping of the garage door opener.

Repeat step 2 to code a maximum of 20 transmitters onto the garage door opener.

To master erase the receiver, press and hold 'K2' button, the LED dot will flash, keep holding for approximately 8 seconds until the LED display flashes a 'C'. Release button. All transmitters are now deleted.

### 3. Safety reverse force adjustment

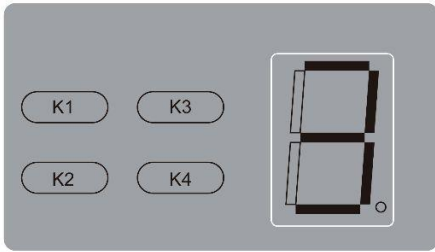

Press and hold 'K1' until the LED displays '3'. It's under force adjustment mode. LED will show the current force level, 1 to 9.

Press the 'K3' button to increase the force level and the 'K4' button to decrease the force level, then press the 'K1' button to confirm.

The maximum force level is 9, the minimum is 1. Please make sure the photo beams is connected and can work properly before you choose levels 4~9.

### 4. Auto-close setting

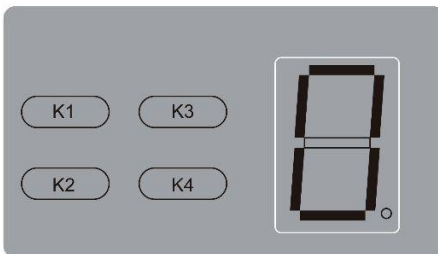

Press and hold the 'K3' button, the LED will display the current setting, 1 to 9 (the factory default setting is '0'). Press the 'K3' button once, and the auto-close time will increase by 1 minute, the maximum time is 9 minutes. Press the 'K4' button once, and the auto-close time will decrease by 1 minute. The auto-close function will be turned off when LED displays 0. Press the 'K1' button to confirm. When the auto-close function is activated, the fully opened door will auto-close after the set time.

### 5. Photo beam setting

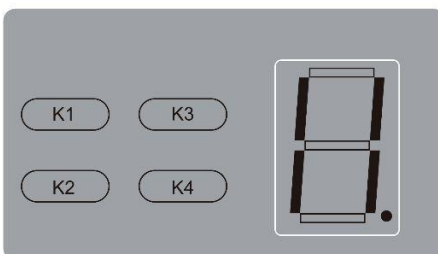

Press and hold the 'K4' button until the LED displays 'II'. Press the 'K3' Button once, the LED will display 'H', photo beam function is activated. Press the 'K4' button the LED will display 'II' to cancel this function. Press 'K1' to confirm. Make sure that the connected photo beams is controlled by switching value, and wiring as Fig. 16

**Notice:** If the photo beam function is activated, while the photo beam is not connected, the door will not close.

### 6. O/S/C Terminal

Connecting a push button to this terminal (Fig. 17), you can use the switch inside the garage to control the opening/stopping/closing of the door when maintaining or the transmitter is lost.

## Special function introduction (optional)

### 1. Flash light function

There are corresponding interfaces for this function and provide 24v-35v flash light voltage. Connect the flash light with DC 24v-28v,current  $\leq 500\text{mA}$ (Fig.19). When use AC 230-240V power flash lights, please match an adapter, and wiring as required (Fig.20 p.12). Upon opening or closing the light will flash as a safety function

### 2. Pass door (SD) protection

This function ensures that the door can't be opened unless the small pass door is closed.

The door panel won't be damaged. Connect according to Fig.18 p.12

### 3. Holiday lock out

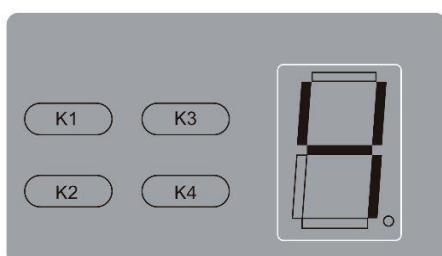

#### HOLIDAY LOCK OUT ON/OFF

Press and hold **SET** (K1) until the LED display setting number **4**, release **SET** (K1). It is now in holiday lock out program.

Press **UP** (K3), LED display **1**, holiday lock out is now activated or press **DOWN** (K4), LED displays **0**, holiday lock out is now de-activated. Press **SET** (K1) to store your settings.

The GDO will allow one opening and closing. After closing, allow 2 seconds for lock out to activate

Note: When the GDO is in lock out mode, the DTS TX5 Octo is the only transmitter that can be used to open the GDO. First press button '3' (Fig. A) followed by programmed button within 2 seconds

Fig. A



# Wiring Guide

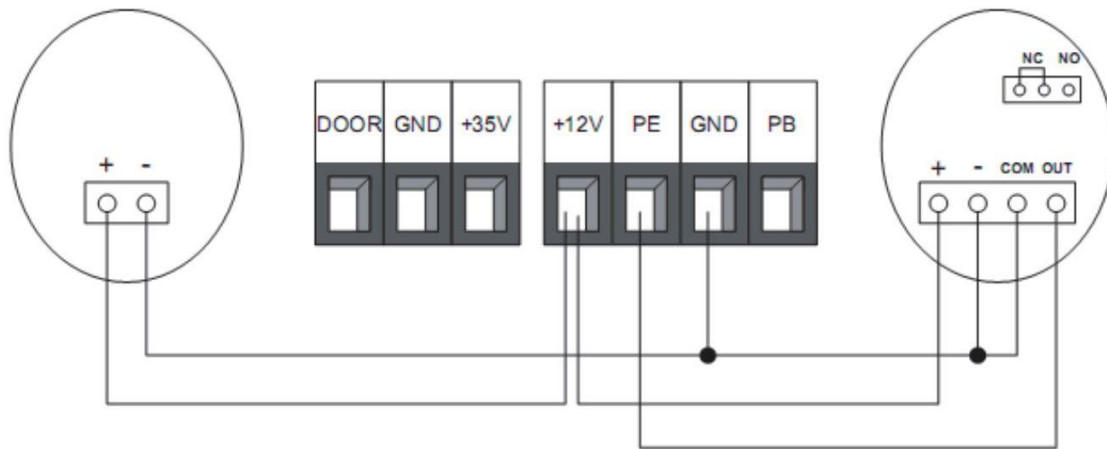

NO/NC photo beam

Fig.16

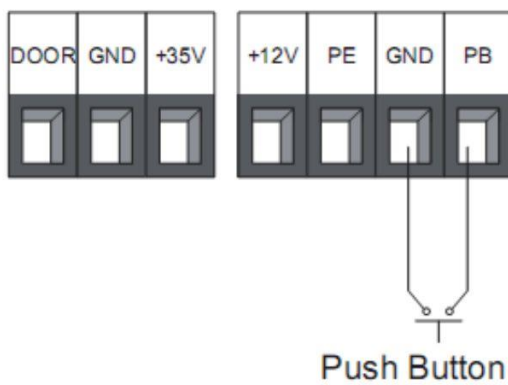

Fig.17

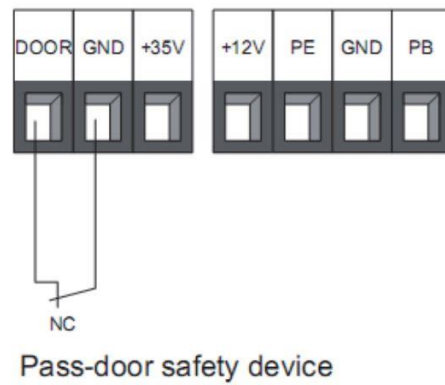

Fig.18

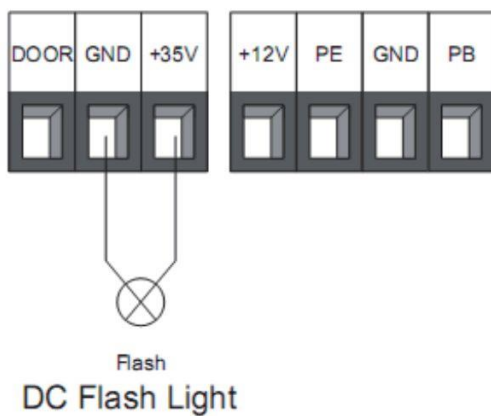

Fig.19

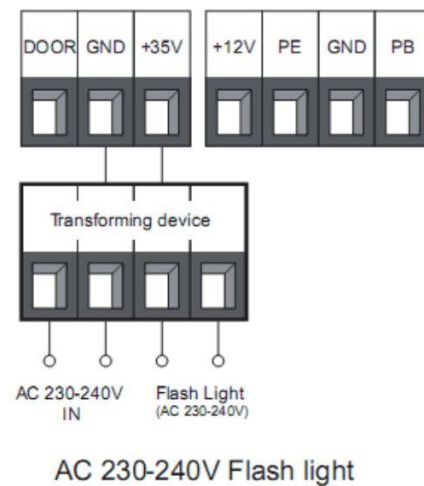

Fig.20

## Manual disengagement

The opener is equipped with a manual release cord to disengage the shuttle and move the door by hand while holding the handle down (Fig.21). Pull on the handle to disengage the shuttle. To re-engage the door simply run the opener in automatic mode or move the door by hand until the trolley engages in the chain shuttle. In some situations, if a pedestrian door is not in state, it is recommended that an external disengagement device should be fitted (Fig.22).

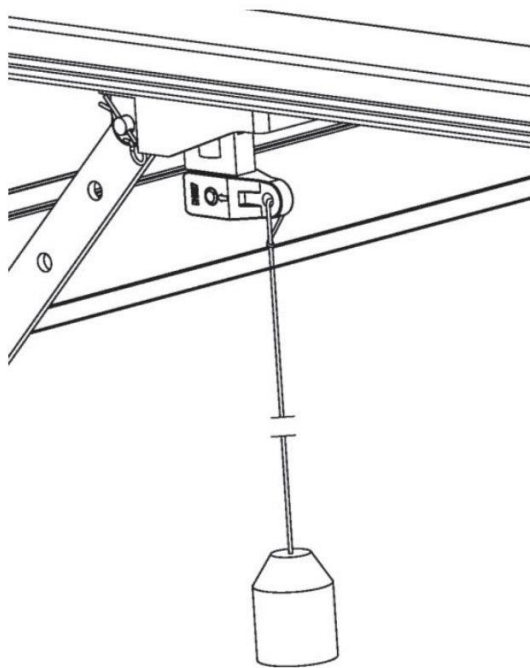

Fig.21

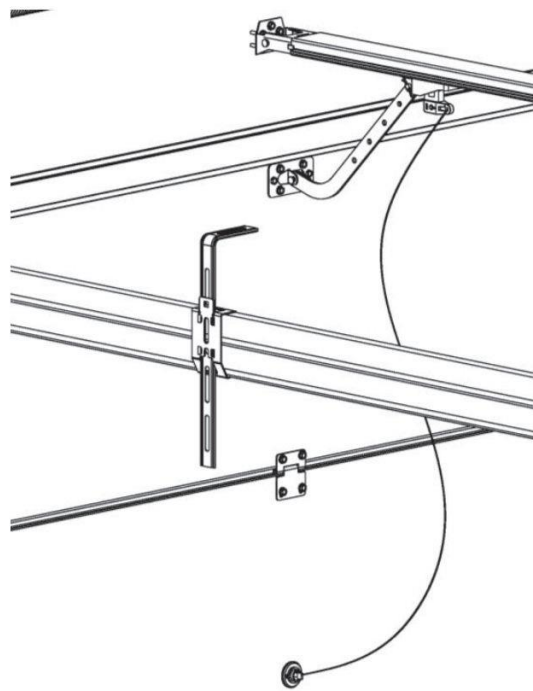

Fig.22

## Maintenance

No particular maintenance is required for the logic circuit board. Check the door at least twice a year if it is properly balanced, and if all working parts are in good working condition or not. Check the reversing sensitivity at least twice a year and adjust if it is necessary. Make sure that the safety devices are working effectively (photo beams, etc.)

## Final notes

This manual is only used by technical persons who are qualified to carry out the installation.

No given information in this manual can be considered of any interest to the end user.

It is important for the installer to show their clients the correct operation using of the opener including the use of manual disengagement cord.

Inform the owner about the need for regular and accurate maintenance, especially regarding regular checks of the safety and reversing devices.

## Important information for the user

Once the opener has been installed, the user must be informed about how it works and all the risks that can arise if it is used improperly. The user must avoid placing themselves in dangerous situations such as standing within the door's operating range when it is moving.

Do not let children play near the door, and keep the remote controls out of their reach.

All services, repairs or checks must be carried out by professionally qualified persons and noted on a maintenance register kept by the user.

**IMPORTANT NOTE:** In the case of a malfunction the user must call an authorized installer and should not attempt to repair it by yourself.

## Technical Specifications

Model	DTS1000	DTS1000HS
Power input:	220 VAC	220 VAC
Max force:	1000N	1000N
Door opening size:	14m <sup>2</sup> 140kgs	14m <sup>2</sup> 140kgs
Opening/closing speed:	165mm/sec	250mm/sec
Light time:	3minutes	
Working temperature:	-29° ~70°C	
Relative humidity:	<90%	
Radiofrequency:	433.92MHz	
Decoding:	Rolling code	
Backup battery:	24V 3.5AH	
Lamp:	LED 12VDC	



## Standard packing list

Item	Quantity
Door opener	1
Track (incl. Traveller)	1
Transmitter	2
Door bracket	1
Wall bracket	1
“U” bracket A	2
“U” bracket B(If aluminum track)	1
Iron angle A	2
Track bracket	1
Clutch cord	1
Cord pendant	1
Straight arm	1
Bent arm	1
Fixing kit	1

## General error code

Code	Failure	Possible causes	Proposed solutions
E1	No signal Detected on main hall sensor	Main hall sensor loose	Check & fix connection between Main hall sensor and PCB A.
E2	No signal Detected on sub hall sensor	Sub hall sensor loose	-Check & fix connection between sub hall sensor and PCB A. -Power off and restart the device
E3	Sub hall count faster than main hall	Main hall sensor and sub hall sensor wire switched	Swap main hall sensor and sub hall Sensor wire on PCB A, learn travel Limit again.
E4	Wicket door terminal open circuit	-Wicket door is open -Wicket door Connecting wire is loose.	-Close the wicket door -Fasten the wicket door connecting
E5	Motor not working	-Incorrect type motor is used -Motor is damaged	-Replace with a correct type motor -Replace with a new motor
E6	Door blocked During closing	-There's object under The door -Stuck between door	-Move away object under the door -Adjust door installation & reset travel limit

## Manufacturer's warranty

- All goods manufactured by DTS Security Products carry a 12 month factory warranty from date of invoice.
- All goods are warranted to be free from faulty components and manufacture.
- Faulty goods will be repaired or replaced at the sole discretion of DTS Security products, free of charge.
- This warranty is subject to the goods being returned to the premises of DTS Security Products.
- This warranty excludes lightning damage, insect damage and damage caused by faulty installation.
- In the event of the goods being supplied by dealer, merchant, agent or duly appointed installer of DTS Security Products, the claim must be directed to that supplier.
- The carriage of goods is for the customer's account.
- This warranty is only valid if the correct installation and application of goods, as laid out in the applicable documentation accompanying said goods, is adhered to.
- All warranty claims must be accompanied by the original invoice.
- The liability of DTS Security Products and / or their distributors is limited as herein set out DTS Security Products and / or their distributors will not be liable for consequential or incident damages howsoever arising.