



SLIDING GATE MOTOR

INSTRUCTION MANUAL

Expert 500
Elite 600

7 Belgrade Ave, Spartan.
Sales: 011 392 5540
Technical: 082 460 7832

www.dtssecurity.co.za

PRECAUTIONS:

Please carefully read and follow all instructions provided prior to starting the product installation process.

1. A qualified or recommended professional must perform all installation, repair, and servicing.
2. Always ensure that the path is clear of people, pets, or obstacles before activating the gate opener.
3. Avoid crossing the path of a moving gate and keep individuals and objects clear of its area.
4. It is important to keep children and pets away from the gate controls.
5. To prevent unauthorized individuals from using gate openers, keep all accessible gate opener controls secure.
6. Do not make any changes to the automated system's components in any way.
7. Before performing any work on the system, ensure to cut off the electrical power supply and disconnect the batteries.
8. A separate double pole isolator must be fitted within 1 metre from the gate opener.
9. Safety devices must be installed to prevent accidents caused by moving machinery, such as crushing, dragging, or shearing.
10. The installer should demonstrate the manual operation of the gate during an emergency and provide the User/Warnings guide to the user.
11. Ensure all authorized gate users understand associated hazards by communicating safety instructions.
12. Regularly check the function of the obstruction detection system and safety devices.
13. DTS Security Products will not be held liable for any damages resulting from misuse or use of the product for unintended purposes.
14. This product is designed and manufactured only for the purposes outlined in the documentation. Any other use may compromise its performance or pose risks.
15. Please note that any actions not explicitly mentioned in these instructions are strictly prohibited.

BASE PLATE MOUNTING INSTRUCTIONS

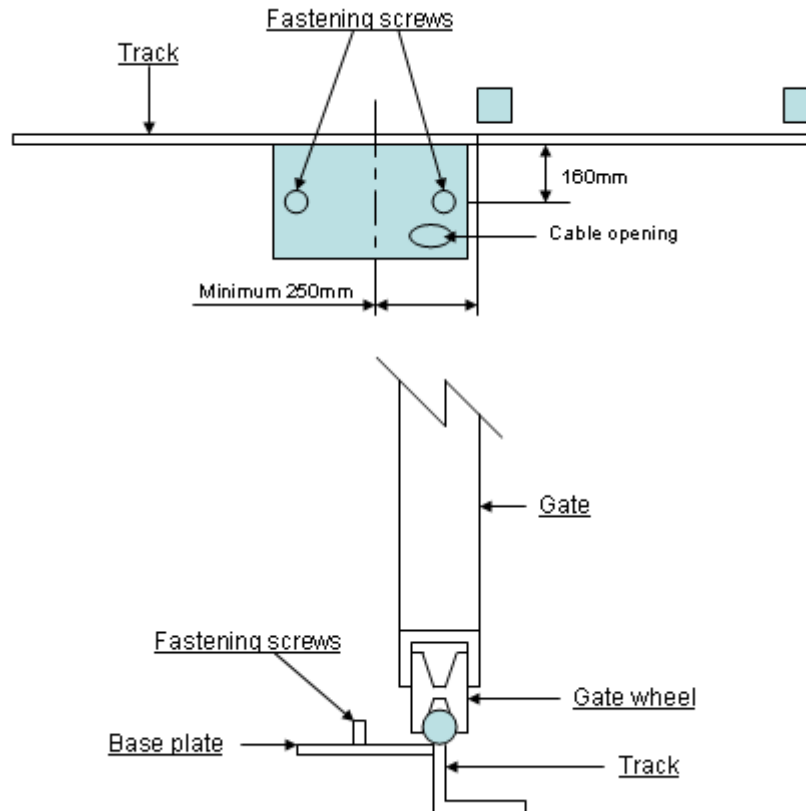

1. Assemble the base plate by fastening the M10x30 Hex set screws into the base plate from the bottom up and tightening it into position – all new gate motors supplied by DTS will be provided with the base plate already fixed.
2. Mount the base plate with bolts, 160mm from the centre of the gate track and the centre of the base plate a minimum of 250mm away from the gate opening.
3. Secure the base plate to the gate track by welding it directly to the gate track. (Ensuring a distance of 160mm from the centre of the gate track to the centre of fastening screws).
4. Fit all required cabling through the hole provided in the base plate.
5. Support the back of the base plate with 40x40x3 angle iron (not provided) or similar off-cut steel knocked approximately 300 to 400mm into the ground.
6. Fill area below and around the base plate with approximately 300x400x300 concrete to ensure that the motor will be secure.
7. **NOTE** – For **SAFETY** reasons, **ALL** motors should be fitted with a set of IR beams.

Note:

When connecting intercoms to the control card (N/O IT and CMN), please ensure that your intercom trigger output is potential free (**ZERO voltage**). If not, a gate relay module **must** be fitted.

GEARBOX MOUNTING INSTRUCTIONS (ALL MODELS)

1. Fit gearbox over mounting bolts protruding from base plate.
2. Slide gate fully open and closed, ensuring pinion gear has approximately 5mm clearance to gate at all times.
3. Fasten gearbox down firmly to base plate using M10 washers and nuts.

How to override the gate motor for manual operation

1. Unlock and open the override lever on the gearbox.

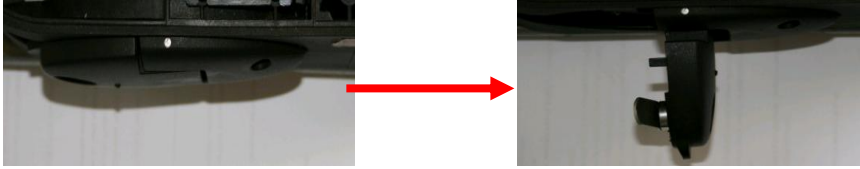

2. The gate can now be opened and closed manually.

Please note: the activation of the manual release may cause uncontrolled movement of the driven part due to mechanical failures or an out-of-balance condition.

RACK MOUNTING INSTRUCTIONS

1. Unlock and open manual override lever fully to disengage gearbox. (See above).
2. Using a 2.5 to 3mm spacer between the pinion gear and the rack, mount the rack using Tek screws (No. 12x20 - not provided) and screw the rack to the gate starting from the tail of the gate and ensuring that the rack is mounted level.
(A 2.5 to 3mm spacer can also be put between motor and base plate when fitting rack. This must be removed once the rack is in place).

NB: Ensure that one of the screws attaching the nylon rack to the angle is in line with the read switch or limit switch spring when the gate is fully closed and open position.

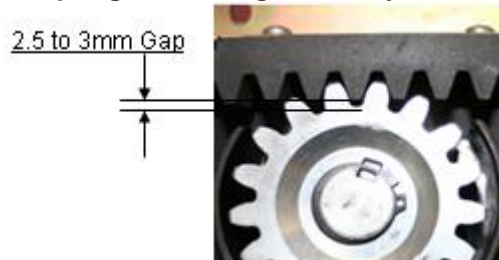

LIMIT SWITCH ACTUATOR MOUNTING INSTRUCTIONS

1. Remove the screw attaching the nylon rack to the angle that is closest to the position of the reed switch or the spring on the motor when the gate is in the close and open position.
2. Fit limit switch actuators with screws provided onto the nylon rack.
3. Setting the gate close actuator – Close the gate with approximately 15-20mm gap between gate and close stopper. Now move the actuator until the close LED lights up. Fasten the actuator.
4. Setting the gate open actuator – Open the gate with approximately 15-20mm gap between gate and open stopper. Now move the actuator until the open LED lights up. Fasten the actuator.
5. **The gate must never bump against the close or open-end stoppers.**

Magnetic limit actuator



Spring limit actuator



Important: For safety reasons, a solid stop must be fitted at **both ends** of the gate to prevent the gate from moving past its full open or close position.

ON BOARD RECEIVER PROGRAMMING

Only compatible with DTS TX Octo remotes.
(The override lever must be closed for programming transmitters).



PROGRAMMING A TRANSMITTER (TX) FOR FULL OPEN OPERATION – GATE (Version 1.3)	PROGRAMMING A TRANSMITTER FOR PEDESTRIAN OPERATION – PED (Version 1.3)
<ol style="list-style-type: none">1. Push the GATE button, the RX led will go on.2. Push the required button on the transmitter, at arm's length from PCB once, the Rx led will flash. Press the same button again, and the PCB will emit 3 beeps for a full Keelog transmitter.3. Repeat Step 1 and 2 for additional transmitters. Up to 500 transmitters (Slots) can be programmed as a joint combination between GATE & PED.	<ol style="list-style-type: none">1. Push the PED button, the RX led will go on.2. Push the required button on the transmitter, at arm's length from PCB once, the Rx led will flash. Press the same button again, and the PCB will emit 3 beeps for a full Keelog transmitter.3. Repeat Step 1 and 2 for additional transmitters. Up to 500 transmitters (Slots) can be programmed as a joint combination between GATE & PED.

Important: The TX button used for GATE cannot be used for PED and vice versa.

To individually erase transmitters:

To erase a button from the receiver, in case of incorrect programming i.e. blue button should be for GATE and not PED. Simply push and hold the GATE button for 5 seconds, the board will give 1 beep. Release the GATE button. Then push and release the TX button you want to erase; the PCB will beep twice as confirmation. The TX is erased and can be learned into correct input.

To master erase:

Push and hold the GATE button, after 5 seconds the board will give 1 x 1 second beep. Keep holding for another 5 – 10 seconds then the board will give 1 x 2 second beep (Older version PCB's will give 2 beeps). Release GATE button. The green receiver (RX) led will also flash 5 times indicating all transmitters erased.

Note: When programming TX no.500, the PCB will give 1x 1.5 second beep after pressing and releasing the GATE button indicating, Receiver (RX) is full. The RX will abort programming automatically. A TX must then be deleted before a next TX can be programmed to the RX. If a transmitter is already programmed, the RX LED will go off with no beep on the 1st press from the TX.

List of STAT LED indications.

- LED ON when open limit is activated. (gate open).
- LED OFF when close limit is activated. (gate closed).
- LED flashing SLOW (1 sec. on/1 sec. off) (gate is in motion).
- LED flashes 2 long/3 short continuously (gate is stopped midway).
- LED flashes fast (250ms on/250ms off) continuously. (gate in overload).
- LED flashes 3 fast flashes every 1.5 seconds. (Battery low, <11VDC).
- LED flashes 1 slow/2 fast continuously. (NO 220 VAC power present)

DTS EXPERT 500 / ELITE 600

ELECTRONICS

Features:

1. Standard mode.
2. Easy motor direction change.
3. Auto close facility. (Infra-red beams must be fitted if auto close is activated).
- 3.a Party mode. (Auto close override)
4. Condominium / Free exit loop facility.
5. P.I.R.A.C. (Passive Infra-Red Access Control) facility.
6. Slowdown (Ramp down) facility.
7. Tamper alarm facility.
8. Anti-hijack.
9. Holiday Lockout.
10. Energy saving mode (Selectable)

1. Standard Mode. (No function selected).

When the gate is activated it will open and can be stopped in mid cycle by pressing the transmitter or manual push button. Pressing the transmitter or push button can reverse the gate. In standard mode the gate will remain on its open limit until it is triggered to close.

If main power fails, the motor will still operate until battery reaches 9.5 volt. Gate will then remain closed (Open if condominium mode is selected). Use the override lever to put the motor on manual.

When the main power comes on again, lock in the override lever and after the battery has charged up, the motor will function as normal (not applicable to high access transformers).

2. Easy motor direction change. (Dipswitch 2).

By selecting the dipswitch, the motor direction and the limit wires are changed automatically. Dipswitch 2 ON, gate closes to the right. Dipswitch 2 OFF, gate closes to the left.

3. Auto close. (Dipswitch 3 ON).

(Infra-red beams must be fitted if the auto close is activated).

When Auto close is activated and the Gate opens to the open limit, the Gate will wait for the pre-programmed time before automatically closing. If the gate is triggered while it is in its closing cycle, it will stop and reopen.

If the transmitter or manual push button is pressed while the gate is in its opening cycle, the gate will stop and close after the preprogrammed auto-close time (from any position, not only from the open limit)

3a. Party mode. To override the auto close (Dipswitch 3 ON), wait till the gate reaches its open limit, then press & hold the transmitter or manual push button for approximately 6 sec. (The control card will give one long beep to confirm the override) To reactivate the auto close, press the transmitter or manual push button.

4. Condominium/free exit loop (Dipswitch 4 ON) (IR beams must be fitted)

When the unit's condominium/free exit loop is activated, the unit will not respond to any transmitter or manual push button while in its opening cycle or open position. When the gate is on the open limit, the unit will automatically wait for the pre-programmed auto close time and then close (even if the auto close function is not selected, i.e. dipswitch 3 is off). When the gate is in its closing cycle, and the transmitter or manual push button is pressed, it will stop and open. Auto close cannot be overridden in condominium mode. (No party mode). If the main power fails, the motor will still operate until the battery reaches 9.5 volts. The gate will then remain open.

Change to manual by overriding the motor with the override lever. When the main power comes on again, lock in the override lever, and the motor will function normally.

5. P.I.R.A.C (Passive Infra-Red Access Control) (Dipswitch 5 On)

With P.I.R.A.C mode activated, if the gate is in its opening cycle and the IR beam is activated, the gate will stop and close immediately after the IR beam is triggered. This will happen even if auto close has not been selected. (Be aware of this factor should a trailer be in tow!!!!)

6. **Slowdown (Dipswitch 6)**

With the dipswitch selected ON, the gate will have a long close and open controlled slowdown distance of 1000mm, and with the dipswitch OFF, the close and open controlled slowdown distance will be 500mm.

NOTE—(A 1000 mm slowdown distance is recommended if the limit is continuously being overrun). The slowdown distance can be programmed (between 500mm and 1000mm) by selecting dipswitch 1 and 6 to the ON position. Push and hold the BT Set button, and count the beeps; 1 beep equals 100mm. Release the BT Set button at the required distance, and switch both dipswitches OFF.

7. **Tamper Alarm Facility**

If the courtesy light feature is not used, then the relay can be re-configured as a general Tamper alarm output. An alarm will sound if the gate is moved from the closed position without a valid trigger. Re-configuration is achieved with the following procedure.

A) Three-minute Latching tamper (Siren – N/O relay contact) output.

Make a note of the option dip switch settings, then remove the power (AC and DC) from the control PCB and open the gearbox release. Switch all dip switches to the OFF position, then select dipswitch 1 and 6 to the ON position. Reconnect the power to the PCB, and after approximately 2 seconds, choose dipswitch 1 and 6 to the OFF position.

The setting is confirmed by 1 to 5 beeps (depending on where the load pot setting is).

Select the dipswitch settings back as per your notes. Close the gearbox release and perform the standard power-up calibration routine.

B) Impulse tamper (Alarm – N/O relay contact) output. Repeat section A) using dipswitch 1 and 5.

C) Normal Courtesy light mode. (No Tamper alarm). Repeat section A) using only dipswitch 1.

D) Continuous alarm output. Repeat section A) using dipswitch 1 and 4.

The tamper alarm will automatically arm itself when the gate is in the closed position and will trigger the alarm relay if the gate is moved or forced off the closed limit switch without a valid trigger.

If latching mode is configured, the relay will switch every 3 minutes until the alarm is restored.

If impulse mode is configured, the relay will trigger only once.

Any valid gate or pedestrian input trigger will cancel the tamper alarm, which will automatically re-arm once the gate is again in the close position.

The alarm can also be turned off for maintenance by opening the gearbox release and pressing the remote-control push button (confirmed by three short beeps). It will remain disabled until the gearbox release is closed and the gate closed position is re-confirmed.

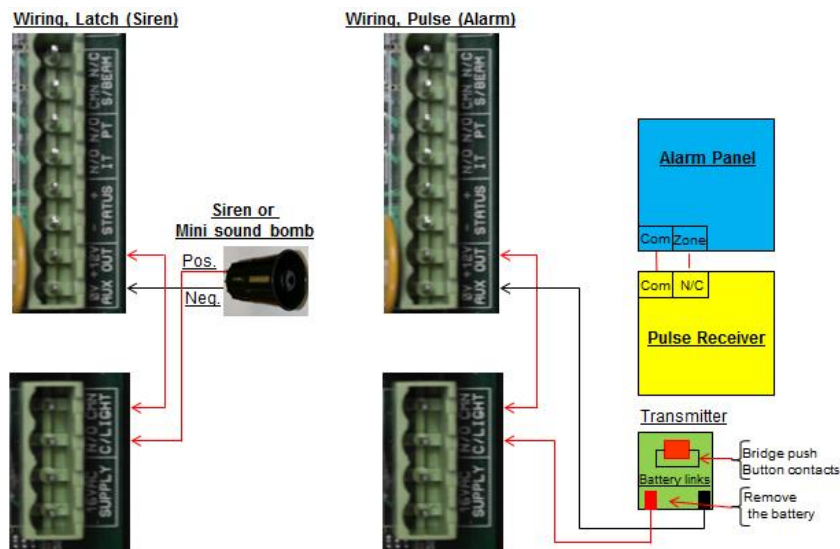

8. **Anti-hijack**

When the tamper alarm function is active, and the gate receives a valid trigger, but is obstructed and cannot move or does not move more than 150mm, the alarm or siren will activate.

9. **Holiday Lock-out facility** (This function must be programmed in).

(To program the above, follow the alarm function procedure but utilize dipswitch 1, 5, and 6.)

To activate the holiday lock-out (the gate must be in the closed position), press and hold any pedestrian trigger function (on the remote) for approximately 13 seconds. After approximately 13 seconds, the PCB will give one three-second beep as an acknowledgement that the holiday lock-out is now activated. To de-activate holiday lock-out, repeat the above process. The PCB will, in this instance, give five 1-second beeps as acknowledgement and de-activate.

10. Energy saving mode (Selectable by Jumper) (Only applicable on the Multi PCB's)

If jumper is bridged over the two pins, that will turn off the power saving mode.

When the jumper is removed, power saving mode will be active.

N.B. If an external receiver is fitted, the power for this receiver must be connected directly to the battery connection and not to the 12V auxiliary output, as the auxiliary power switches off when no AC (220V) or solar power is detected for 3 minutes. (Saving battery life). When in energy saving mode, the PCB will rectify itself on an input trigger.

POWER CONNECTIONS

Low voltage (OBT) (25 VA) transformer – 220V at the gate. (Expert 500 has a 500m/Amp fuse)

(Connect also for 16VAC plug-in transformer)

Connect 220V AC wires to the input side of the 500/16volt AC transformer

(Live/Earth/Neutral) connector on the side of the transformer, then connect the two output wires (red) to the 16VAC connectors on the controller card.

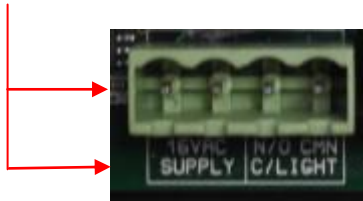

High access power supply unit – 220V at the motor. (Elite 600, 120VA has a 2 Amp fuse.

Connect 220V AC to the LEN (Live/Earth/Neutral) connector on the side of the power supply unit.

Black lead from the power supply unit connects to – (neg) HA connection on the PCB.

Red lead from power supply unit connects to + (pos) SUP connection on PCB.

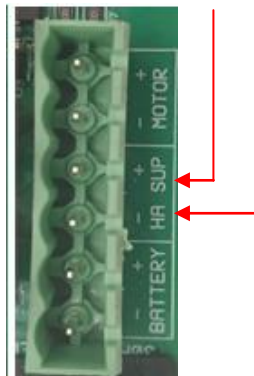

DO NOT CONNECT 220V DIRECTLY TO PCB.

Please note: When 220V is used at the gate motor, a separate double pole isolator must be fitted within 1 metre from the motor.

COURTESY LIGHT OUTPUT (Will stay on for 3 minutes after a trigger is received)

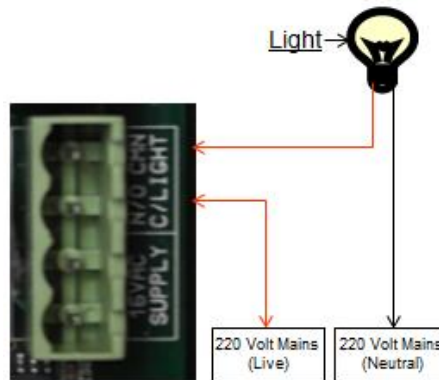

Please note that the Amps usage on the courtesy lights must not exceed 10 Amps.
(If this facility is not being used, it can be used as a tamper alarm facility; see page 9).

DO NOT CONNECT 220V DIRECTLY TO PCB UNDER ANY CIRCUMSTANCES.

DO ALL RUNTIME (Calibrating) AND TRANSMITTER PROGRAMMING BEFORE CONNECTING ANY ADDITIONAL INPUTS SUCH AS, – INTERCOM, EXTERNAL RECEIVERS, BEAMS, ETC.

Diagram to connect IR Beams to PCB

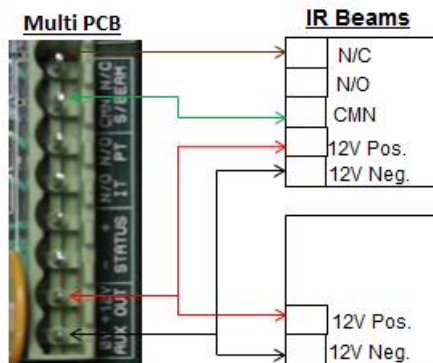

Important – Remove the fitted bridge by S/BEAM connected between CMN & N/C.

If **no beams** are fitted, a bridge must be equipped between CMN & N/C.

Note: If sentry beams are fitted, then **S/BEAM, N/C** on the PCB must be connected to **N/O** on the Beam

NOTE- IR beams **must** be fitted if auto-close is activated.

Dipswitch selections to activate a function.

Dipswitch 1 – Programming.

2 – Motor direction (This can only be changed before programming or if neither limit switches are activated).

3 – Auto-close (IR beams must be fitted).

4 – Condominium mode (IR beams must be fitted).

5 – P.I.R.A.C. mode (IR beams must be fitted).

6 – Slow down distance

Dipswitch selection for programming. (With dipswitch 1 ON)

Dipswitch 3 – Auto-close. (Infra-red beams must be fitted if the auto close is activated).

Dipswitch 4 – Pedestrian (Open distance and auto close time).

DO NOT CONNECT 220V DIRECTLY TO PCB.

PROGRAMMING

1 – Run Time (Calibrating) Setup (With total power up, AC and DC, on PCB)

- Unlock and open the override lever on the gearbox.



- Open the gate manually, approximately 1 metre.
- Close and lock the override lever on the gearbox. (PCB should beep 1-5 beeps pending on load pot setting)



- Pull the gate in any direction until the gear locks in.
- With all dipswitches OFF (excluding dipswitch 2 depending on motor direction), press & release the TEST/SET button.
- Gate will close, open and close again and stop on the close limit. (Motor speed can be increased during open cycle by pushing and holding down the TEST/SET button, but release the button approximately 500mm before the close and open position). The final closing cycle of programming will automatically run at normal speed.
- Control card will beep twice to confirm end of program run time (calibrating) setup.

NOTE:

- 1) If gate opens first, dipswitch number 2 is wrongly selected.
- 2) Gate will automatically calibrate every time the power is restored after a total power failure, irrespective of present dipswitch selection.
- 3) The controller will drive the gate approximately 6mm past the closed limit activation position. Allowance must be made for this when setting the limit actuators.

2 – Auto close (Default 10 seconds) (Infra red beams must be fitted if auto close is activated).

- Switch Dipswitch 1 and 3 on.
- Press & hold TEST/SET button.
- PCB will Beep (1 Beep = 1 Sec of auto close time) (Maximum 180 seconds).
- Release TEST/SET button at required auto close time.
- Switch Dipswitch 1 and 3 off.
- Switch Dipswitch 3 back on to activate the auto close.

3 – Pedestrian Opening (Default 1 metre / 10 seconds auto close)

- Switch Dipswitch 1 and 4 on.
- Gate must be in the closed position.
- Press & Release TEST/SET Button.
- Gate will open.
- Press & release TEST/SET button to stop gate at required pedestrian opening distance.
- Press & Hold TEST/SET button to program auto close time required.
- Control card will Beep (1 Beep = 1 Sec of auto close time) (Maximum 120 seconds).
- Release TEST/SET button at required pedestrian auto close time.
- Switch Dipswitch 1 and 4 off.
- Gate will close again.
- Do not switch dipswitch number 4 back on.

To reset factory defaults.

Remove all power from the PCB. Hold down the TEST/SET button and re-connect the AC power, with AC power now on, release TEST/SET button. PCB will give one 2-second-long beep followed by 1-5 beeps, depending on load setting on pot, as acknowledgement.

Load setting

To adjust the load, turn the provided load pot to determine the load setting (Minimum, anticlockwise & Maximum, clockwise). The control card will beep, 1 minimum to 5 maximum beeps on next trigger before movement.



LIST OF AUDIO INDICATIONS AND WARNINGS.

- | | |
|---------------------|---|
| One continuous beep | - PCB is damage, replace PCB. |
| One 1.5 second beep | - "Party mode" has been activated. |
| One 2 second beep | - Factory defaults have been set. |
| One 2 second beep | - Beams are incorrectly wired or faulty when programming the motor.
or Runtime was aborted for whatever reason. |
| One 3 second beep | - Holiday lockout mode has been activated. |
| One 3 second beep | - Gate triggered when motor is in 3-minute overload lockout. |
| One 3 second beep | - Check beam condition or no bridge between CMN & Beam N/C |
| Two 400 ms beeps | - Run time programming (calibrating) has been successful. |
| Two 1 second beeps | - Pedestrian mode was activated.
or No AC power is present, running battery power only. |
| Three 200ms beeps | - Battery power is too low, or
Override function is open or faulty. |
| Four 100ms beeps | - Motor is in holiday lockout. |
| Four 200ms beeps | - Check motor/load fuse (25amp).
- Check motor brushes and armature.
- PCB reader not picking up Magnet on motor. |
| Five 1 second beeps | - Holiday lockout mode has been de-activated. |
| Twenty 100ms beeps | - Motor has stalled or overloaded, then check the following points:
1) Gate pulling force (should not exceed 12.5kg on the Expert and 15kg on the Elite).
2) Load pot is set too low (Turn pot completely clockwise)
3) Battery voltage under load (12volt) (Not connected)
4) Gearbox gearwheel. |

FOR SAFETY REASONS.

**Infra-red beams are recommended for
all gate motor installations.**

PCB Control card.

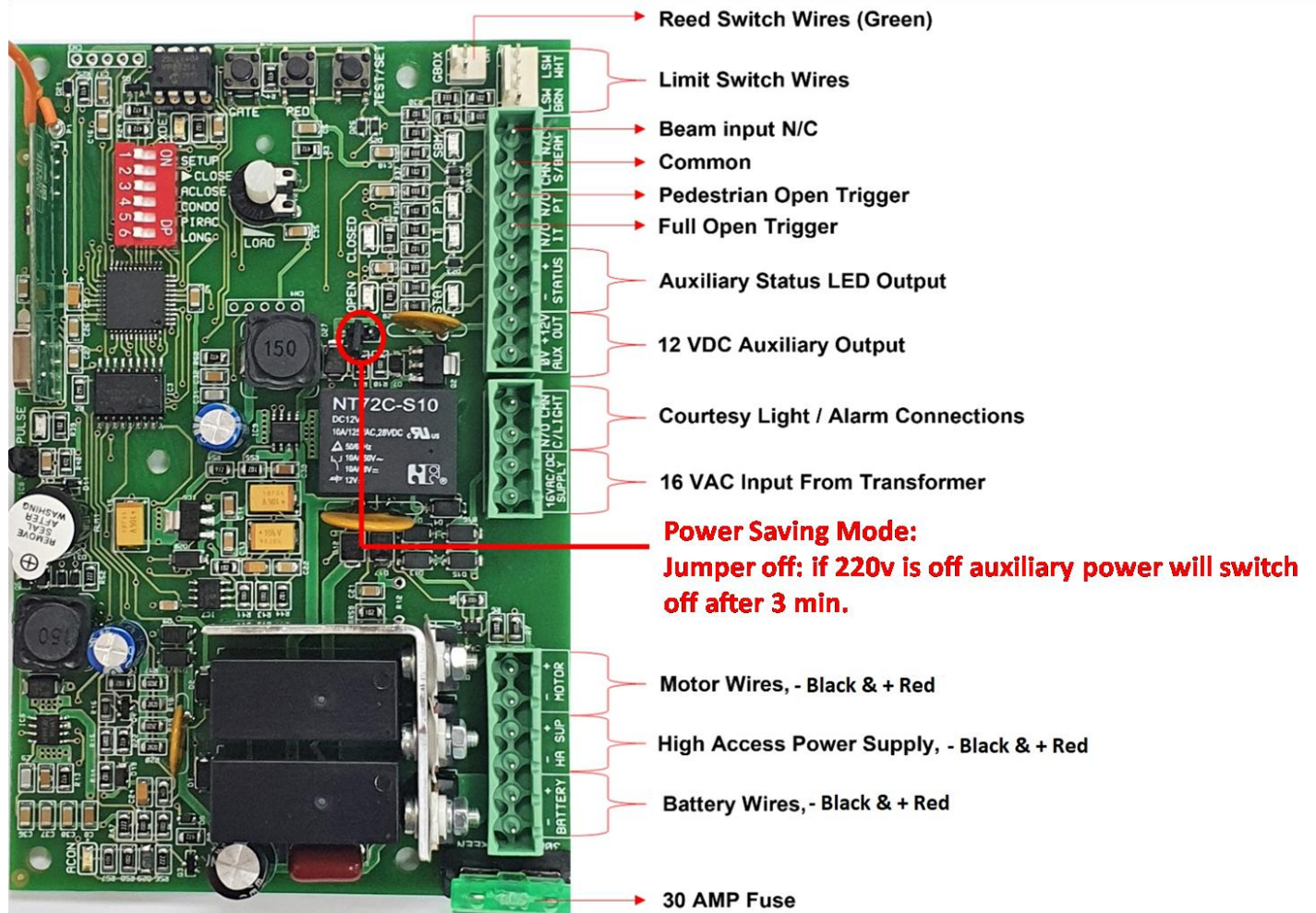

NB – When connecting intercoms to the control card (IT and CMN), please ensure that your intercom trigger output is potential free (**ZERO voltage**). If not, a gate relay module **must** be fitted.

Please ensure that the auxiliaries connected to the 12-volt auxiliary output does not exceed 500 m/Amps in total. (If so, remove from 12V auxiliary output and connect directly to battery)

TROUBLESHOOTING:

FAULTS	CAUSES	ACTION
<p>When pressing the remote transmitter or manual push button the gate operator will not respond at all.</p> <p>When pressing the remote transmitter, the PCB gives 3 beeps and does not move but the 12v 7AH battery is OK.</p> <p>PCB responds but gate will not open.</p> <p>PCB responds by giving 4 very quick 100ms beeps but will not open.</p> <p>PCB responds by giving 4 200ms beeps but no movement.</p> <p>Charge rate drops to +-7 volt.</p>	<p>Transmitter battery flat.</p> <p>Transmitter or manual push button is physically damaged.</p> <p>Transmitter has not been programmed into the receiver memory or manual push button is not connected to the PCB or push button.</p> <p>The override reed switch in the gear box is faulty or failing to make connection between PCB and reed switch or the magnet in the override door is missing.</p> <p>Condominium /loop option is not activated, and the battery has reached its low level. (9.5Volt).</p> <p>Motor is in holiday lockout.</p> <p>Motor/Load fuse is faulty, motor brushes not contacting armature or battery is disconnected.</p> <p>12 Volt aux. outputs of 500m/Amps have been exceeded.</p>	<p>Replace transmitter battery.</p> <p>Check with supplier.</p> <p>Follow the receiver setup instructions. Check wiring between PCB and push button.</p> <p>Replace the reed switch and or the magnet. (For short term solution, bridge out the two pins on the PCB where the reed switch wires should go).</p> <p>Check the household main supply, the transformer or Power Supply Unit and all related cabling.</p> <p>Press and hold the pedestrian remote or manual push button connected to PT on PCB for approximately 13 seconds until PCB gives 5 long beeps.</p> <p>Replace fuse. Repair or replace (if shorter than 7mm) motor brushes. Re-connect battery.</p> <p>Remove some of the auxiliaries. (Can connect them to the battery directly)</p>
<p>Before operating, the unit gives two 2beeps on opening but not on closing.</p>	<p>The primary supply has failed, and the unit is running on battery reserve.</p>	<p>Check the household main supply, the AC transformer or DC Power Supply Unit and all related cabling.</p>

<p>The gate opens but will not close.</p> <p>The gate will not activate when pressing TEST/SET And gives a 3 second beep.</p>	<p>The primary supply has failed, and the unit is running on battery reserve with the condominium/loop option selected and it has reached its low battery limit. (9.5Volt)</p> <p>Safety infra-red beams are obstructed, or the beams equipment/cabling are faulty or incorrectly wired.</p> <p>There are no beams fitted and the CMN & N/C at S/BEAM is not bridged.</p>	<p>Check the household main supply, the transformer or PSU and all related cabling.</p> <p>Clear obstruction, repair or replace safety infra-red beams equipment/cable, fix incorrect wiring connections.</p> <p>Connect a bridge between CMN & N/C at S/BEAM.</p>
<p>The gate when closing stops and reverses or when opening stops.</p> <p>OR</p> <p>Gate runs a short distance and stops.</p>	<p>The unit is sensing an obstruction</p> <p>The infra-red beam has been triggered.</p> <p>Another trigger has been received by the control card.</p> <p>Encoder is faulty.</p>	<p>Clear obstruction or adjust load sensing.</p> <p>Clear obstruction.</p> <p>Check with other operators on the system.</p> <p>Turn ring magnet on the motor by hand: if no activity on the encoder LED, contact supplier. (Check that the PCB is fitted correctly)</p>
<p>Gate does not remain open.</p>	<p>Auto close has been activated.</p> <p>Another user has triggered the unit.</p> <p>Condominium/loop (Dipswitch 4) has been activated.</p>	<p>De-activate auto close or use auto close override.</p> <p>Check with other operators on the system.</p> <p>De-activate condominium / loop mode.</p>
<p>When the beams input is triggered, the gate stops and reverses during opening cycles.</p> <p>If the gate on programming does not run-in slow speed.</p>	<p>P.I.R.A.C. mode (Dipswitch 5) has been activated.</p> <p>Gate is closing in the wrong direction.</p> <p>The MOS-FET on the PCB is blown or faulty.</p>	<p>De-activate P.I.R.A.C. mode</p> <p>Dipswitch 2 is selected incorrectly.</p> <p>Replace the PCB.</p>

<p>The unit gives two beeps and opens partially and stops, gives two beeps and then closes.</p> <p>Gate opens fast but closes slowly.</p>	<p>The pedestrian (PT) mode on the PCB is being triggered.</p> <p>A transmitter code has been programmed incorrectly into the pedestrian (PED) function of the receiver.</p> <p>Lost contact between release switch and PCB.</p> <p>Lost open limit connection after gate stopped on limit</p>	<p>Check equipment /cabling attached to the pedestrian (PT) on the PCB input.</p> <p>Delete the transmitter and re-program the transmitter into the receivers (GATE) as per instructions.</p> <p>Check contact between read switch and PCB (Green wire)</p> <p>Move actuator and or motor closer to each other.</p>
<p>When gate reaches a limit actuator, the unit does not stop running.</p>	<p>Limit input wired incorrectly (out of sync' with the motor direction.)</p> <p>Limit switch is faulty.</p>	<p>Re-wire</p> <p>Change limit switch or check with supplier.</p>
<p>Gate motor is jumping teeth on the rack.</p>	<p>Pinion to rack spacing is incorrect.</p> <p>Rack is insufficiently fastened to gate leaf.</p> <p>Debris on track</p>	<p>Re-align.</p> <p>Re-align and correct fastening.</p> <p>Clean track.</p>
<p>Gate jams in the open or closed position and is not easy to manually release.</p> <p>Gate opens pedestrian when full open trigger is given.</p> <p>PCB does not beep 1-5 beeps on closing the override lever.</p>	<p>Gate is running too far.</p> <p>Gate is running past its limit actuator.</p> <p>Gate is overloading in the close position after it received a pedestrian trigger.</p> <p>The magnet inside the override lever is missing.</p> <p>The double green wire reed switch inside the gearbox is faulty.</p>	<p>Adjust the limit actuators until there is a gap between gate and stoppers of approximately 10 – 15 mm</p> <p>Replace the switch, rewire correctly or check limit spring assembly.</p> <p>Move the closing limit actuator towards the closing cycle approximately 10mm.</p> <p>Replace the magnet.</p> <p>Replace the reed switch. (The reset pins on the PCB can be bridged as a short-term solution).</p>

MANUFACTURER'S WARRANTY.

- All motors manufactured by DTS Security carry a 24-month factory warranty from date of invoice. (Excluding batteries & Remote controls).
- Batteries & remote controls carry a 12-month warranty.
(Remote batteries are consumables and therefore carry NO warranty)
- All goods are warranted to be free from faulty components and manufacture.
- Faulty goods will be repaired or replaced at the sole discretion of DTS Security Products, free of charge.
- This warranty is subject to the goods being returned to the premises of DTS Security Products.
- This warranty excludes lightning damage, insect damage and damage caused by faulty installation.
- In the event of the goods being supplied by dealer, merchant, agent or duly appointed installer of DTS Security Products, the claim must be directed to that supplier.
- The carriage of goods is for the customer's account.
- This warranty is only valid if the correct installation and application of goods, as laid out in the applicable documentation accompanying said goods, is adhered to.
- All warranty claims must be accompanied by the original invoice.
- The liability of DTS Security Products and / or their distributors is limited as herein set out. DTS Security Products and / or their distributors will not be liable for consequential, incident damage or injury howsoever arising.